



BARNES™
MOLDING SOLUTIONS

HOT RUNNER TECHNOLOGY

THS Nozzles Series

Product Catalog



Molded part

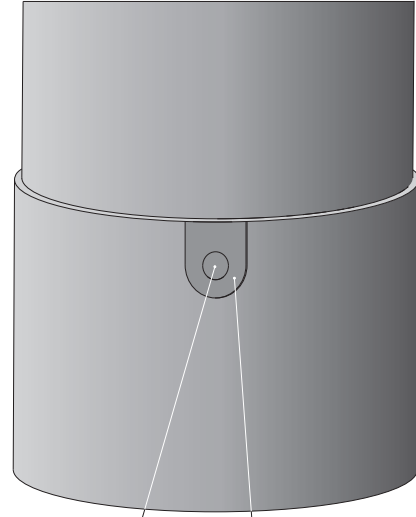
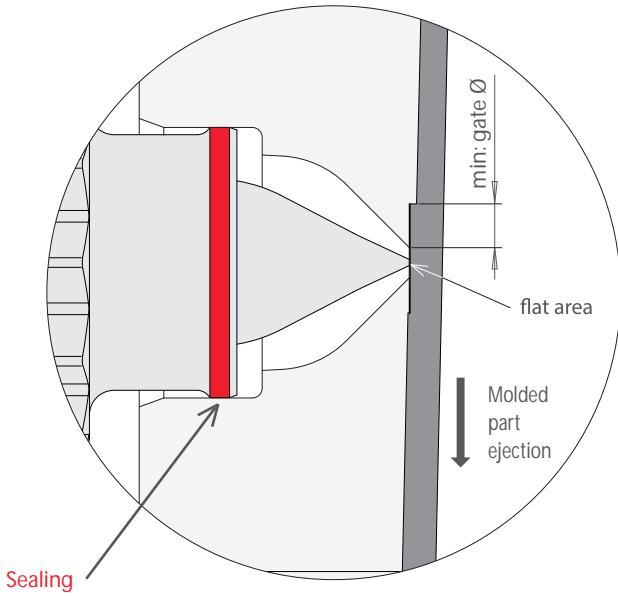

gate flat area
(Not cylindrical) 0° draft angle

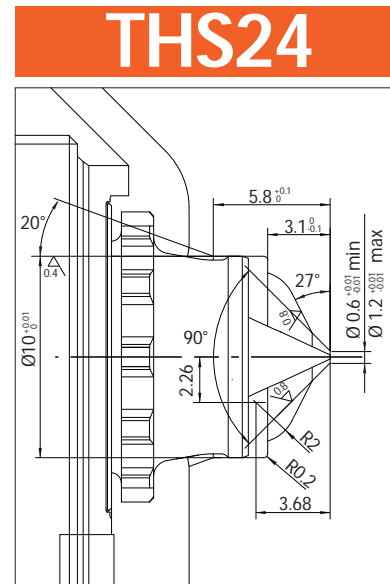
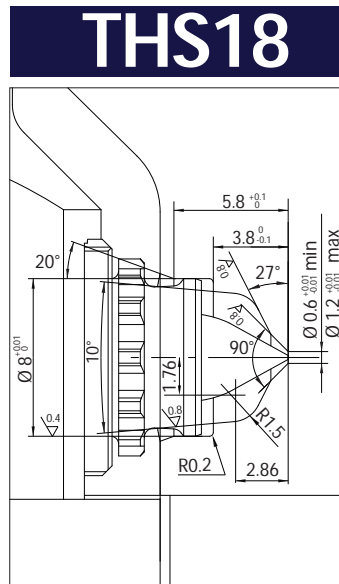
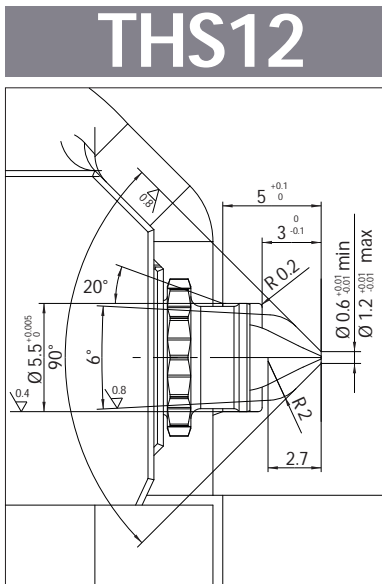

polyole ns
low viscosity

6 g

20 g

40 g

technical
resins

1.5 g

7 g

16 g

Maximum part weight (per gate)



Radial Side Gate

THS12-R1
THS18-R1
THS24-R1

1

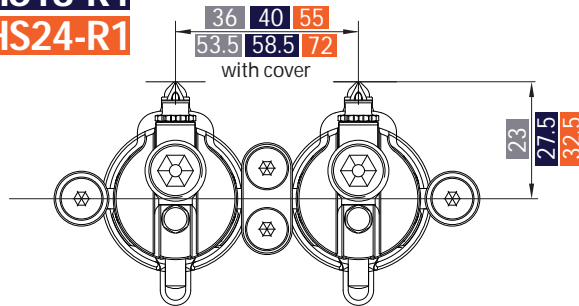

THS12-R4
THS18-R4
THS24-R4

4

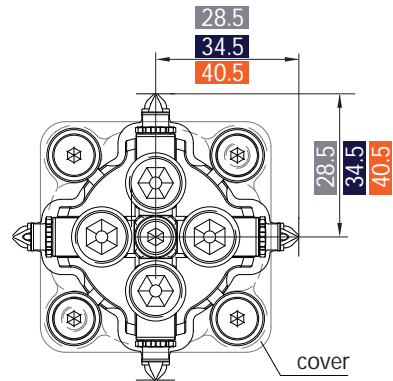

THS12-R2-180
THS18-R2-180
THS24-R2-180

2

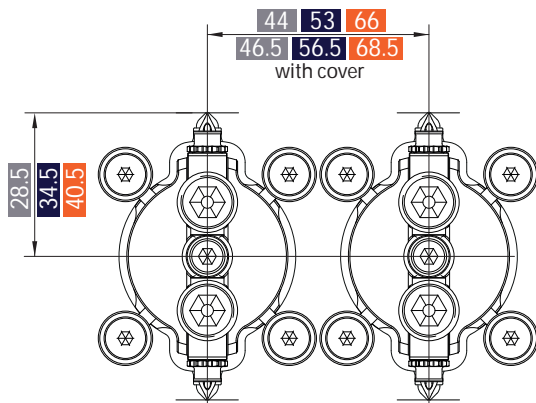

THS12-R2-90
THS18-R2-90
THS24-R2-90

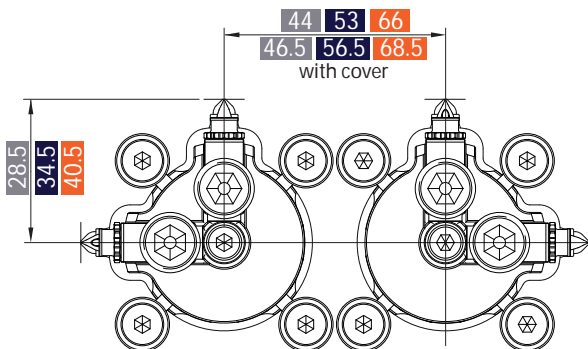

THS12-R8

8

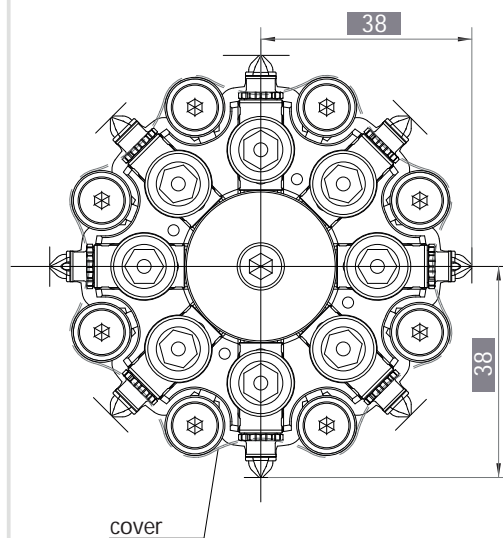

THS12-R1

THS18-R1

THS24-R1

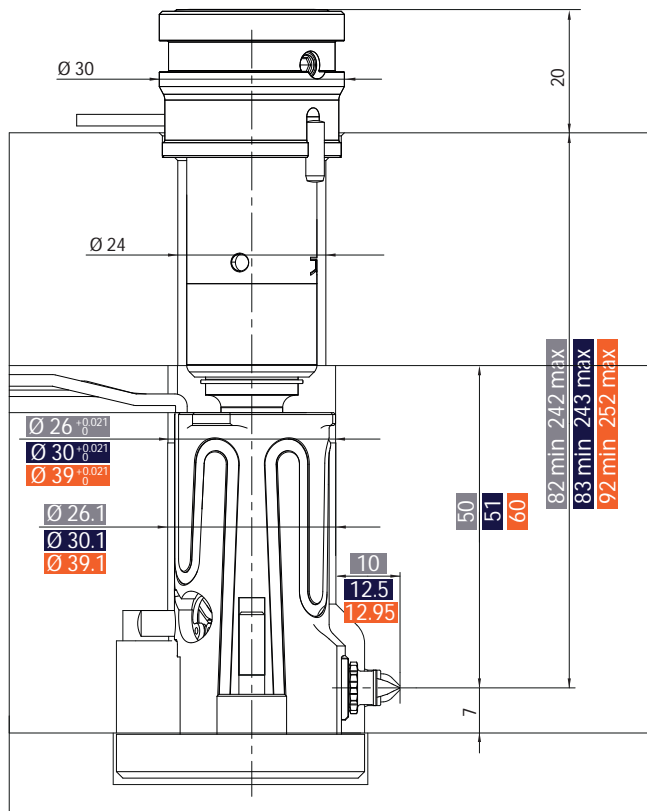
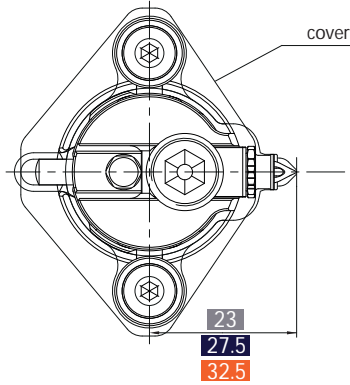

Radial 2 tips 180° side gate

THS12-R2-180

THS18-R2-180

THS24-R2-180

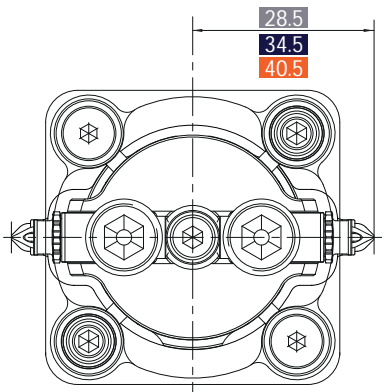

Radial 2 tips 90° side gate

THS12-R2-90

THS18-R2-90

THS24-R2-90

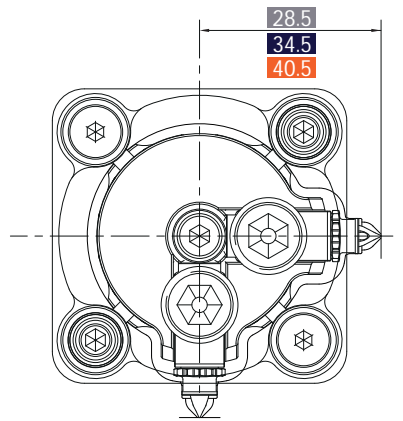

Radial 4 tips side gate

THS12-R4

THS18-R4

THS24-R4

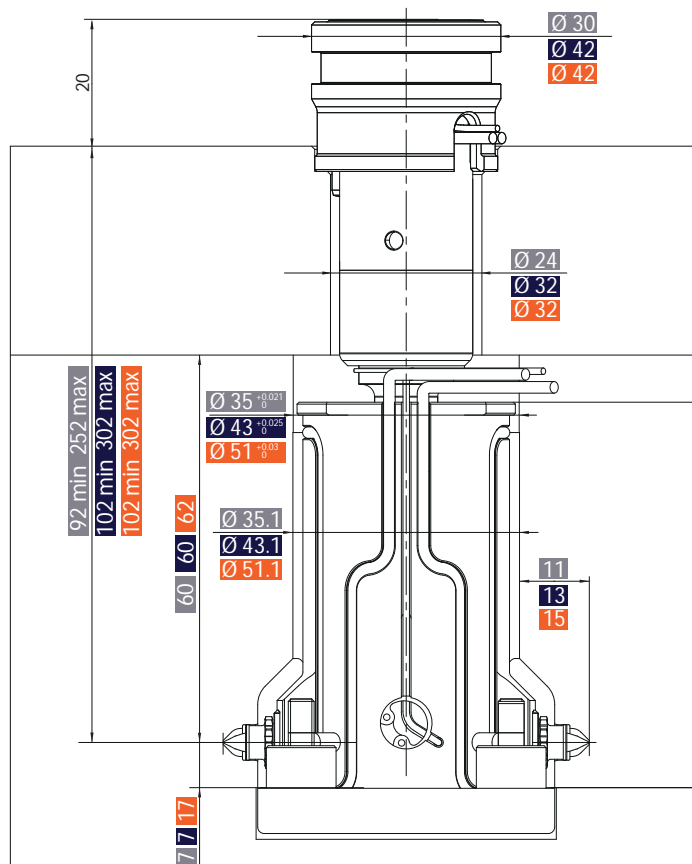
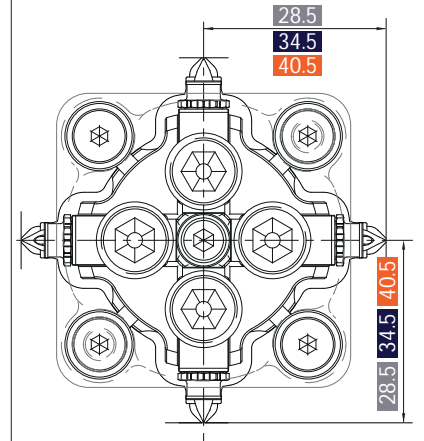

Radial 8 tips side gate

THS12-R8

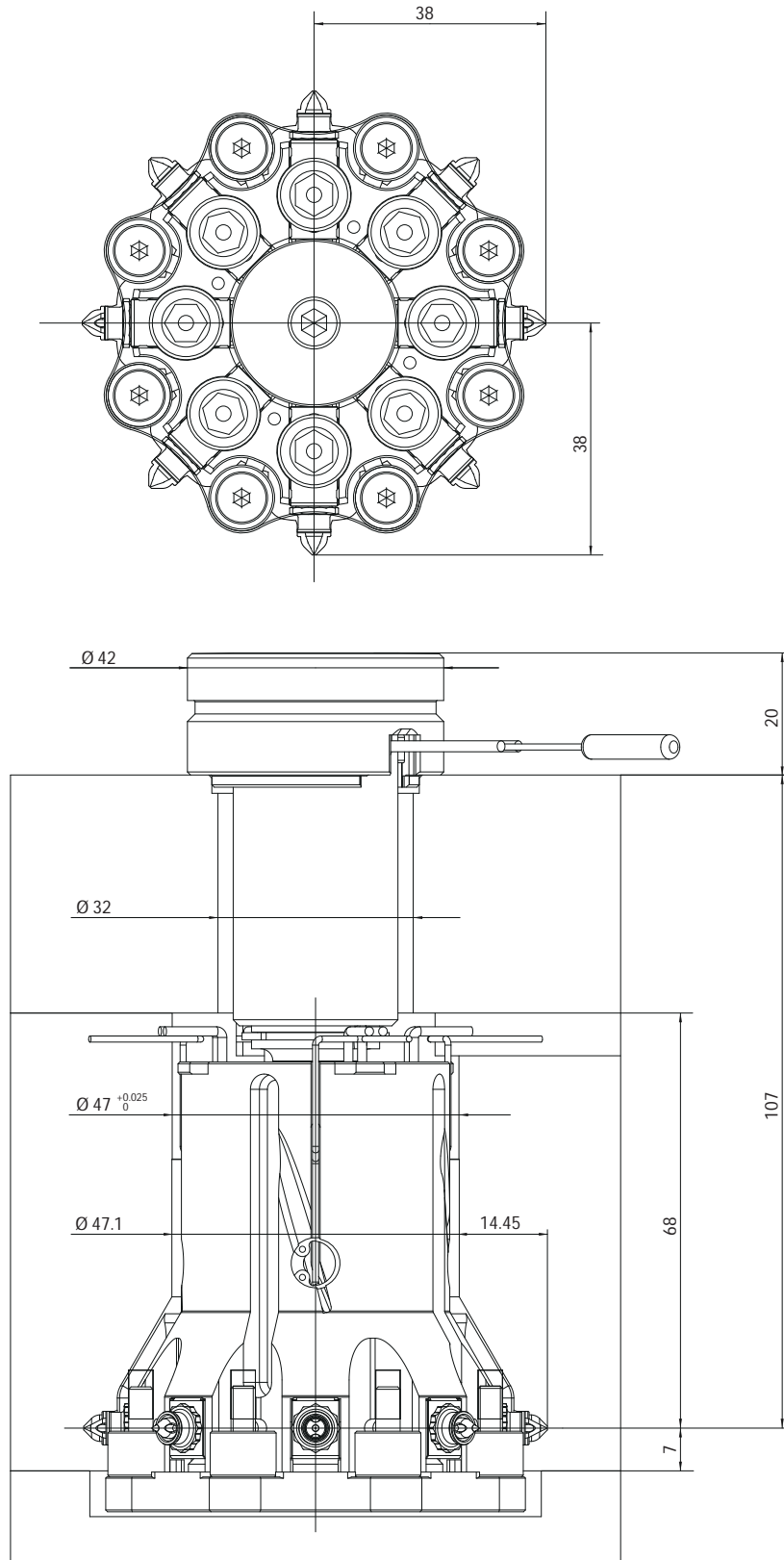



Linear Side Gate

THS12-L-2+2

2+2

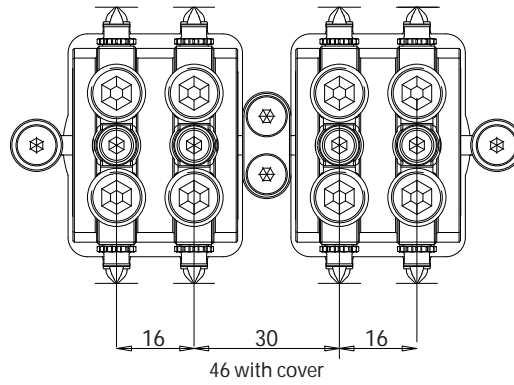

THS12-L-4+4

4+4

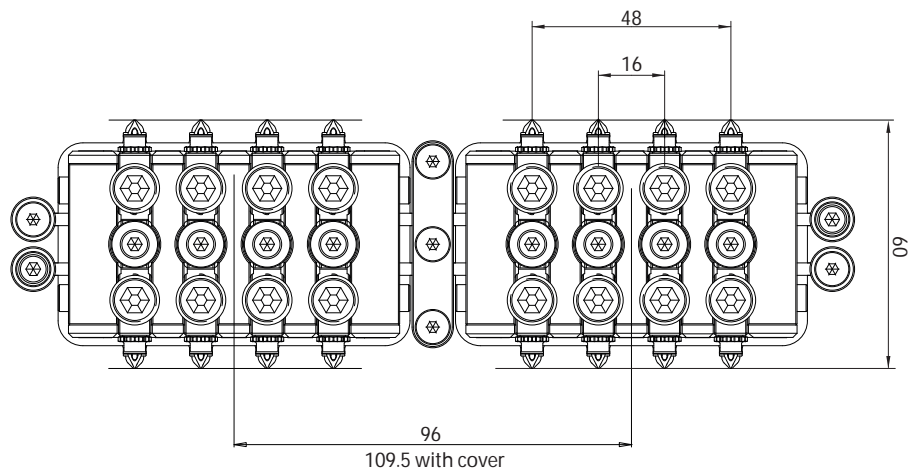

THS12-L-4+4

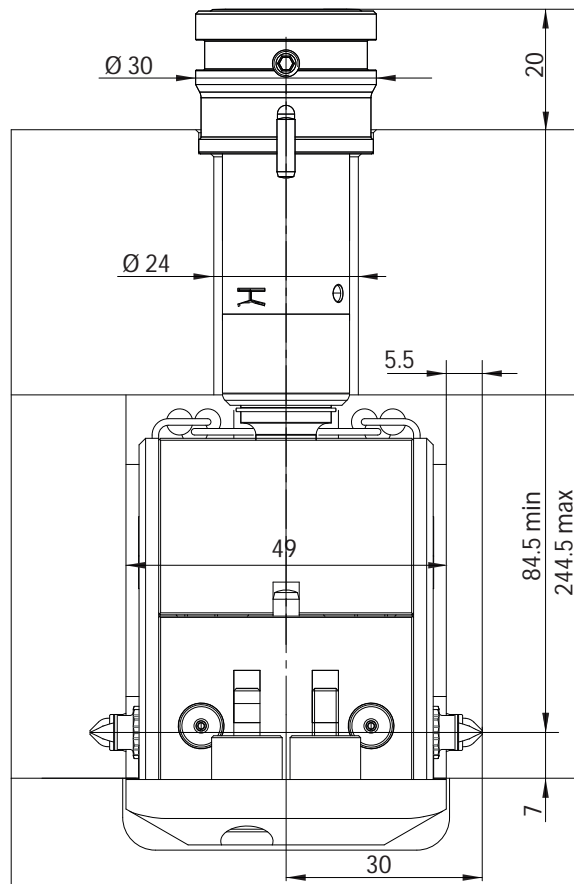
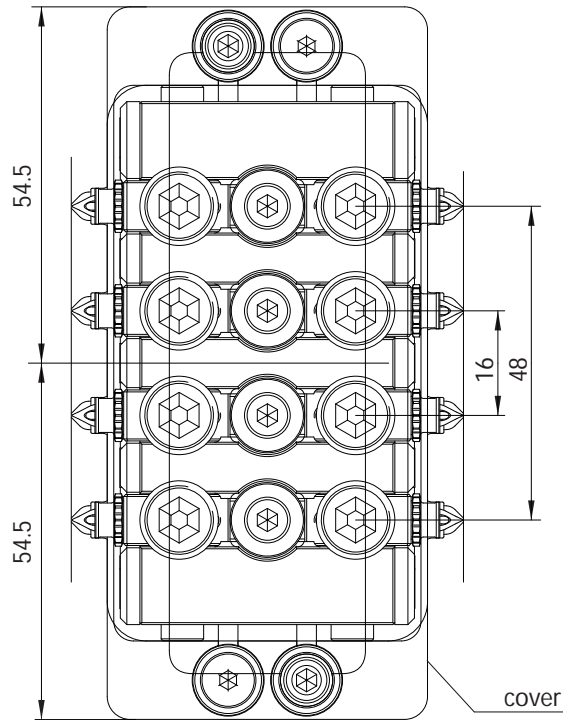



BARNES™
MOLDING SOLUTIONS



www.barnesmoldingsolutions.com

